



Glide Kiosk

Service Manual



Contents

Maintenance Program	page 1
Glide Kiosk Illustration	page 2
Routine Maintenance.	page 3
Troubleshooting	page 4
Parts List.	page 5

Couvrette Building Systems

Headquarters

565 Electric Road
Salem, VA 24153
(540) 375-2608
(800) 800-2608
(540) 375-2638 FAX

California Office

8665 Argent St. Ste. D
Santee, CA 92071
(619) 938-8000
(800) 736-1114
(619) 938-8001 FAX

EMAIL products@couvrette.com • www.couvrette.com

Couvrette Building Systems reserves the right to change the products described in this document without notice in the interest of product improvement.

© 2006 Copyright Couvrette Building Systems. All Rights Reserved.



Kiosk Maintenance Program

Couvrette Building Systems offers a complete menu of maintenance programs for all products. These are available in annual, semi-annual or custom programs. Our maintenance plan includes:

- 1) Verify that kiosk remains level for proper operation of all doors and drains.
- 2) Inspect dry pack at base of kiosk, repair and replace as required.
- 3) Check lockout bolts on top of building and re-silicone if necessary.
- 4) Check caulking around ATM bezel.
- 5) Adjust and examine thermostats and humidistat for proper settings.
- 6) Adjust alignment on turntable when required (turn kiosk only).
- 7) Check seals and caulking, repair or replace as required.
- 8) Examine all locks, deadbolts, and latches for proper operation and lubricate as required.
- 9) Remove circulation fan and lubricate. Clean area of any trash or papers blocking fan guard.
- 10) Vacuum kiosk and electrical access floor.
- 11) Remove, inspect, and clean A/C, condenser coils, grills and cabinet.
- 12) Clean A/C condensation drain tube and check for blockages, cracks and replace if necessary.
- 13) Clean interior walls or repaint when walls are plaster finish.
- 14) Examine electrical connections for loose or disconnected wires.
- 15) Perform continuity and hi-potential electrical test.
- 16) Wash and wax entire building.
- 17) Touch up paint as necessary.

For kiosks with canopies, the following operations will be performed:

- 1) Check caulking between canopy and building.
- 2) Check operation of photo-cell.
- 3) Check operation of all lights and replace bulbs as necessary.
- 4) Clean sign faces.
- 5) Check drain operation - clean/clear as required.
- 6) Roof repair as necessary.
- 7) Wash and wax canopy.

Couvrette will photograph kiosks after each service visit and keep the photo on file for an up-to-date status record. Each kiosk will be tagged at the time of service indicating the date and name of the person performing the service.

Contact Couvrette to sign up for our kiosk maintenance program.

Cutaway view of the kiosk.

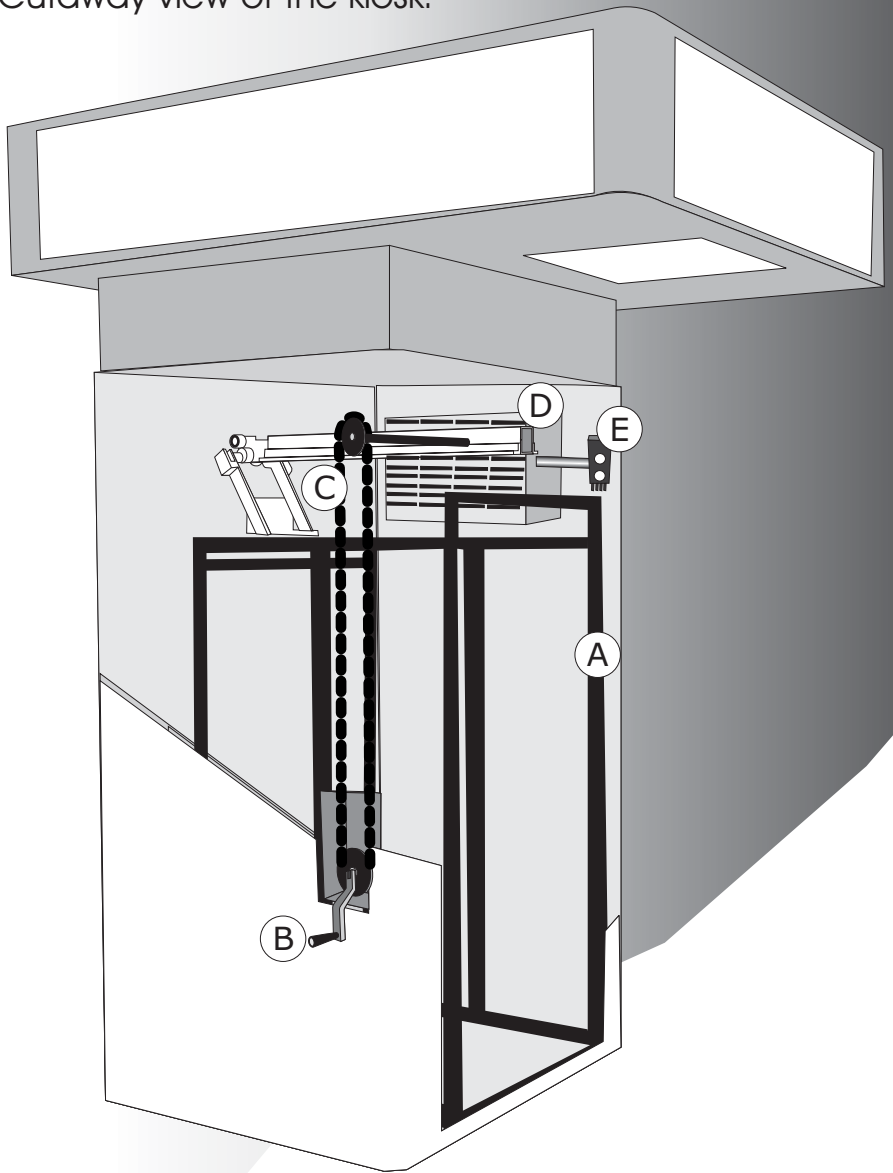

1 Clear any debris from beneath the cage (A) as well as in the glide mechanism (C).

2 Turn the handle (B) clockwise to move the ATM forward. Continue until the ATM is in service position. Perform service operations. Turn the handle counter clockwise to return the ATM to its operating position. Turn until the glide assembly is fully retracted back into the kiosk.

3 Check that the glide chain and gears (C) are properly lubricated with white lithium grease.

4 Replace the AC unit (D) filter, or wash it with soap and water. Verify that the AC drain line is free of kinks and is properly connected. The thermostat (E) for the AC unit is located beside the unit.

5 Clean the exterior of the kiosk with warm soapy water. Do not use harsh cleaners or wax.

- A) Glide Cage
- B) Handle
- C) Glide Gear/Chain
- D) A/C Unit
- E) Thermostat
- F) Bellow



ATM in Out of Service Position

Every 6 Months

- 1) Check thermostat is at 75-78°F.
- 2) Check for and remove debris underneath cage as well as in the glide mechanism.
- 3) Grease glide mechanisms with white lithium grease.
- 4) Grease the fittings, chains, and sprockets of the cranking mechanism.
- 5) Make sure the bellow is in good condition.
- 6) Clean the kiosk exterior with mild soap and warm water.
- 7) Clean the ATM exterior with mild soap and warm water.
- 8) Check and replace kiosk weather-stripping.
- 9) Check cold weather kit (if installed).

The steps below will allow basic troubleshooting of the Couvrette Glide Kiosk. If it is necessary to contact Couvrette Building Systems, please have the unit number of the kiosk ready. This number is located on the circuit breaker subpanel, the UL sticker affixed to the door, and the tie-down floor plate.

1) What if the glide cage is difficult rack out?

- A) Check for debris blocking the path of the glide cage.
- B) If no cause for this problem can be found, call Service Manager at Couvrette Building Systems for further assistance.

2) What if the crank handle is not operating?

- A) Check to see if the chain broke.
- B) If the chain is still intact, call the Service Manager at Couvrette Building Systems for further assistance.

3) What if the glide locks up?

- A) Immediately call the Service manager at Couvrette Building Systems.

4) What if the A/C is not working?

- A) Make sure the circuit breaker on the kiosk subpanel is in the (ON) position.
- B) If no cause for this problem can be found, call the Service Manager at Couvrette Building Systems for further assistance.

NOTE: The A/C-Heat unit is specially wired into the automatic changeover thermostat and cannot be replaced by an off-the-shelf unit provided by a local vendor. Any modifications to the original A/C-Heat unit may affect the operation of the unit. If a service call is required after the A/C-Heat unit has been modified, a service fee may be charged.

5) What if the A/C ices up?

- A) Turn off A/C circuit breaker on the kiosk sub-panel. Allow A/C unit to sit for two hours. Then restore power. Verify the thermostat is set at 75-78°F.
- B) If no cause can be found for this condition, contact the Service Manager at Couvrette Building Systems.

6) What if the lights or receptacles stop working?

- A) Make sure the circuit breaker on the kiosk subpanel is in the (ON) position.
- B) Replace any light bulbs that may have blown.
- C) If no cause for this problem can be found, call the Service Manager at Couvrette Building Systems for further assistance.



Kiosk Subpanel

A/C Parts

A/C Breaker
A/C Sleeve
A/C Sweeper Seal
A/C Thermostat
A/C **Unit**

Canopy

Backlit Can
Camera Port
22" X 28" Plexiglass

Chains/Cable

Cable (ft.) (17 ft.)
Cable Crimps (3/16" Oval)
Stainless Steel Chain — Floor

Crank Handle Parts

Crank Handle
Crank Handle Assembly
Face Plate (Lower Tower)
Face Plate (Upper Tower)
Gear
Shaft (ft.)
Shaft & Drive Coupling
Shoulder Bolt (3/8" X 2-3/4")
Split Bushings
Woodruff Keys

Glide Parts

Cam Roller (ea) (2)
Pulley Shaft (1/4")
Shaft Collar (Collett)

Misc. Parts

48" Bumper Guards w/ Mount Kit
71-30 Money Safe
AHD (After Hours Depository)
Door Panel
Double Wide Deluxe BR Window
High Capacity Counterette
Lock, LSDA
Motor Relay
SU-3-C Pedal Stools
Cassette Carrier Send Button
Cassette Carrier Return Button
Cold Weather Kit

Seals

ATM Gaskets (All)
D Seal (ft.) w/ Adhesive
Perimeter Seal (ft.) -Top of Fascia

**Service
Numbers**

VA 1-800-800-2608
CA 1-800-736-1114